

**Our associates will ensure the tool works properly before you leave the store. If you experience issues with the tool while completing your project, simply bring it back to the Tool Rental Center to get a replacement. If you purchase Damage Protection at the time of your rental, you are not responsible for repair costs for tools that break due to normal use.**

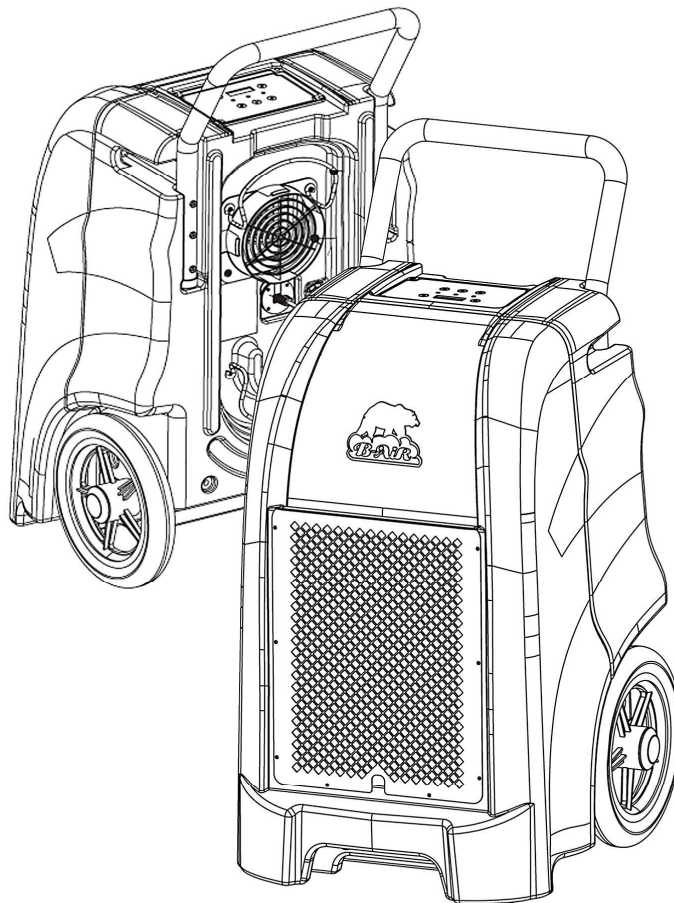

# Industrial Dehumidifier Operating Instructions

**Model: VG 1500**



# Read and save these instructions.

This instruction manual provides important information concerning the use and care of the B-Air Vantage 1500 Commercial Dehumidifier – Model VG 1500. Please read and follow these instructions in order to ensure the safe operation and maximum performance of your unit.

For any questions relating to the use and operation of the unit, please contact: 877.800.2247 or email [info@b-air.com](mailto:info@b-air.com)



**Plug into a grounded 3 prong outlet.  
Do not remove ground prong.  
Do not use an adaptor.  
Use of an extension cord is not recommended (see electrical safety section below)\*.  
Failure to follow these instructions can result in death, fire, or electrical shock.**

## **Electrical Requirements**

For 115V, 60Hz operation, a common grounded outlet on a 15 amp circuit is required. If used in a wet area, a ground fault interrupter (GFI) is required.

## **Built in Electrical Safety**

For your safety and protection, this machine is manufactured with a grounded plug on its power cord. The power cord must be plugged into a properly grounded receptacle. If a grounded receptacle does not exist, have one installed by a certified electrician. Do not cut or remove the grounding prong on the power cord plug. We recommend that this electrical circuit/receptacle operate under a separate breaker or fuse.

\*If use of an extension cord is unavoidable, it must have a minimum of 12 AWG conductors if it is 25 feet long or less and 10 AWG conductors if it is greater than 25 feet long.

## **Water Removal**

The dehumidifier is equipped with an internal condensate pump to remove the water that is collected from the air. This allows the water to be pumped 25 feet with the attached hose. For emptying of the condensate pump for storage see STORAGE section of this manual.

## **REQUIREMENTS FOR SAFE OPERATION**

Never allow unauthorized individuals or children to operate the unit at any time.

It is recommended that anyone operating the VG 1500 wear the proper personal protective equipment and follow safe work practices in accordance with federal, state, provincial and employer regulations.

Check condition of power cord(s) before using them. Damaged cords can cause fatal electric shock and/or equipment damage.

Power cord(s) should never be exposed to water, heat, sharp, or abrasive objects; in addition, they should never be kinked or crushed. Avoid tightly wrapping the cords to prevent kinking of the internal wires. Always replace damaged power cords immediately.

Never pull the unit by the power cord.

Avoid running over power cords with utility equipment and vehicles.

**CAUTION: As with any piece of electrical equipment, always make sure that the unit is turned “OFF” prior to disconnecting it from an electrical outlet. Failure to do so will cause “arcing”, and could result in personal injury, fire hazards and/or damage to the unit. Do not disconnect the power cord from supply receptacle while the unit is operating.**

**WARNING: To reduce risk of electrical shock, do not expose this unit to water or rain – it is certified for INDOOR USE ONLY. Do not touch the electrical outlet or power cord(s) with wet hands or while standing on a wet or damp surface.**

**WARNING: Risk of electrical shock, or contact with moving parts leading to personal injury or death! Turn unit OFF and disconnect power cord from supply receptacle before taking off any removable covers.**

**WARNING: The dehumidifier will restart without warning after a temporary power interruption. If all covers are not in place, the intended protection from the motorized impeller will not be present - keep clear of the motorized impeller to reduce the risk of injury.**

**WARNING: To reduce risk of fire or electrical shock, do not use the AT450S with any solid-state speed control device.**

**CAUTION: For general dehumidification use only. Do not use to dehumidify hazardous or explosive materials and vapors.**

**WARNING:** This dehumidifier is not classified as “intrinsically safe” and should not be used in the following hazardous locations as defined by the Underwriters Laboratories: Class I Division 1, Class I Division 2, Class I Zone 0, Class I Zone 1, Class I Zone 2, Class II Division 1, Class II Division 2, Class III Division 1, Class III Division 2. Refer to the UL web site:

<http://www.ul.com/hazloc/define.htm>.

For use in potentially hazardous locations that fall outside of the above designations, always consult a certified industrial hygienist before use. Do NOT use this equipment in any atmosphere that is or may be immediately dangerous to life or health (IDLH), combustible, flammable, explosive, oxygen deficient, and/or contains odors, vapors, gases or particulates that exceed permissible exposure levels. Such atmospheres may require the use of intrinsically safe equipment, specific engineering controls, and personal protective equipment in accordance with Occupational Safety and Health Administration (OSHA), Environmental Protection Agency (EPA), Canadian Standards Association (CSA), and other federal, state, provincial and local regulations.

**WARNING:** Pressurized Unit. This equipment is factory-charged with R-410A refrigerant and is under pressure. Only qualified personnel should attempt repairs to the refrigeration system. Do not puncture or cut into the refrigeration piping.

**WARNING:** The unit should never be operated without the compressor terminal cover properly secured in place on top of the compressor; otherwise, serious injury or death could result. The cover is required to be securely in place to allow proper operation for the safety overload, and to act as a shield if the hermetic terminals blow out of the compressor shell.

## **OPERATION**

1. Place dehumidifier inside area to be dried.
2. Make sure all windows and doors are closed to the outside and seal off the wet area from any unaffected areas.
3. Route condensate hose into a drain, or a very large container.
4. Press the On/Off button to activate the dehumidifier.

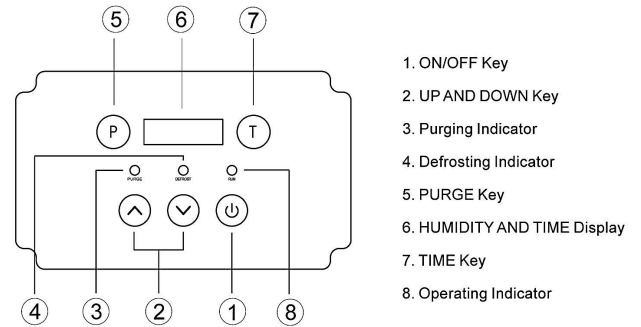

▲ and ▼ :

Press ▲ and ▼ key to set or adjust humidity in the range between 26% and 90%. When the environmental humidity is below 26% “CO” will be displayed.

### **Power Button**

The dehumidifier is turned on or off by pressing the power button. When the dehumidifier is started, the hour meter will display the cumulative hours.

### **Purge Button**

In normal operation, the pump will automatically empty the reservoir. Pressing this button allows manual emptying of the reservoir. Press and *hold* the pump purge button until its reservoir is empty. Always manually purge the water reservoir before transport or storage. Turn off the power and allow the plugged in dehumidifier to rest 5 minutes before the final purge. The purge button can be activated even when the power button is in the off position.

### **Time Counter**

The counter will accumulate and display the total running hours of the unit in 1/10 of an hour. This counter cannot be reset, and therefore might show some hours on a new product that has had quality control testing performed on it.

### **Defrost Indicator**

Under certain conditions, ice may build up on the evaporator coil. When that occurs, the unit will automatically go into a defrost cycle, during which the “Defrost Indicator” lamp will be lit. When the ice has melted, the defrost cycle will end and the system will reverse back to normal operation.

### Defrost Indicator

The defrost indicator lamp will illuminate to indicate the dehumidifier is in defrost cycle. During this period, the compressor is running and the system has reversed.

### Venting/Ducting

Exit air can be ducted on the dehumidifier. Using ducting larger than 6.7" in diameter is recommended.

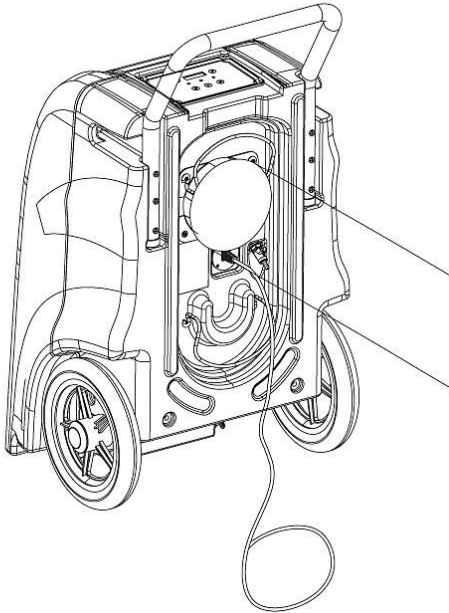

### Transporting

The VG 1500 should be transported upright. When transporting the unit, there is the possibility of water spillage out of the pump reservoir or water drainage off of the wetted evaporator coil. It is therefore important to make effective use of the manual purge feature to evacuate the water out of the pump reservoir before moving the unit. After the OFF button has been depressed, it is recommended that a manual purge be initiated by depressing the PURGE button. Then wait at least 15 minutes for the water to shed off the evaporator and find its way into the pump reservoir. Initiate another manual purge to clear the pump reservoir of any residual water one last time before moving the unit. Disconnect and fully drain the drain hose before coiling it up.

**CAUTION: If the unit has been laid on its back, even for short periods of time, it must be set upright for at least ½ hour before being plugged in and started up. This gives the compressor oil**

**and liquid refrigerant sufficient time to re-distribute. Failure to do so can cause premature compressor failure, and voids the compressor warranty.**

If extremely poor road conditions exist, or excessive shock and vibration are expected, take precautionary measures by padding the unit to provide impact absorption during transport.

**CAUTION: Always be careful when moving the dehumidifier inside a building or home. Older structures with weakened floors and staircases may require special considerations for safe transport.**

### MAINTENANCE

#### Air Filter

Replacement frequency is very subjective, as it depends on the cleanliness of the job site air, as well as the duration of use. The air filter should be checked regularly. Operating the dehumidifier with a clogged filter will reduce efficiency. Operating it without a filter will cause the internal workings to become clogged allowing bacteria and mold to form. The unit can also accommodate a higher efficiency replacement filter of the same physical size and still operate effectively.

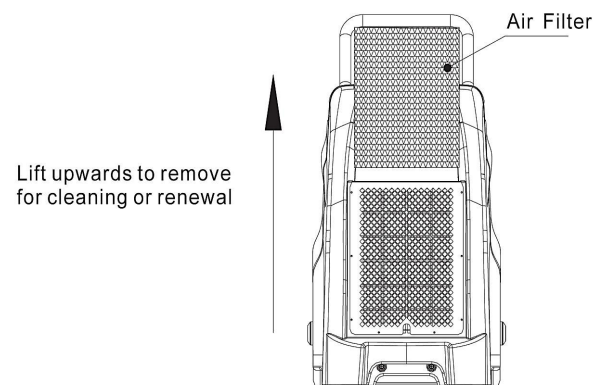

- I. Remove the screws in the four corners of the control panel.
- II. Once the screws are removed, carefully lift the control panel to access the PCB.
- III. On the PCB is a 6F22 9V battery. Remove the battery and replace with new.
- IV. Refit the control panel onto the PCB.
- V. Refit the four screws.

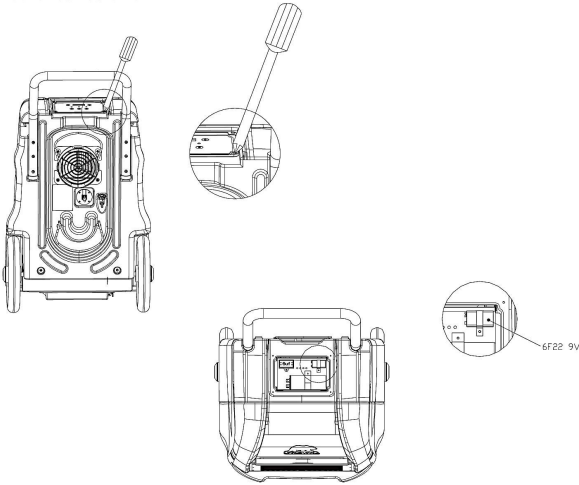

**CAUTION: This dehumidifier is designed to meet or exceed safety and performance standards for dehumidification equipment. Use only manufacturers' replacement parts for service. Use of aftermarket parts voids the product warranty and all performance claims.**

### CLEANING



### **WARNING** **Electrical Shock Hazard**

Turn unit OFF and Disconnect power supply before cleaning. Failure to follow these instructions can result in death, fire or electrical shock.

#### **External Cleaning**

Use a non-flammable mild, non-abrasive soap and clean water solution to clean the dehumidifier. Wipe dry.

#### **Internal Cleaning**

Turn unit off and disconnect dehumidifier from power supply. Clean the core with warm soapy water. Take care to make sure the seal is good as any air leakage will cause the unit to under-perform. Start up the unit and listen for air whistling, if there are any leaks, readjust the brackets.

### STORAGE

Freezing temperatures and biological growth must be considered before storing the dehumidifier. The dehumidifier should be flushed with a bio fungicide before storing. When storing the unit, ensure that water has been removed from the reservoir and hose. This will prevent damage caused by freezing temperatures and to prevent biological growth. Use the pump purge button to remove water and bio fungicide chemicals from the dehumidifier.

### STACKING

DO NOT STACK THE DEHUMIDIFIERS!

### SERVICE

A qualified refrigeration technician must service all refrigerant leaks.

**WARNING: The dehumidifier uses a high pressure refrigerant system and high voltage circuitry, which could present a health hazard, resulting in death, serious bodily injury, and/or property damage. Only qualified service people should service this unit.**

The serial data plate is located on the rear panel of the dehumidifier.

For service information contact: 877.800.BAIR (2247) or email [warranty@b-air.com](mailto:warranty@b-air.com)

## **LIMITED MANUFACTURER'S WARRANTY**

The manufacturer warrants that goods sold to the original user shall be free from defects in material and workmanship as follows:

1-year parts and labor on the entire unit.

- DAY 1-15: A unit that fails within the first 15 days after the sale to an end-user may be eligible to be replaced with a new unit at the sole discretion of the manufacturer. All transportation costs will be covered for the customer.
- DAY 15-YEAR 1: A unit that fails between 15 and 365 days after sale will have parts and labor charges covered under warranty, but transportation charges are to be paid by the customer. Transportation costs include travel charges by repair personnel, or shipping charges to move the unit to and from a repair location.

The manufacturer will not be responsible for:

1. Useful filter life / replacement filters.
2. Damage due to failure to perform normal maintenance as outlined in the Instruction Manual.
3. Failure to start due to voltage conditions, blown fuses, open circuit breakers, or any other damages due to the inadequacy or interruption of electrical services.
4. Damage or repairs needed as a consequence of any misapplication, abuse, neglect, unauthorized alteration, improper servicing, or operation, including operation outside the voltage and frequency limitations as stated on the unit rating plate.
5. Damage as a result of flooding (immersion), fires, lightning, freezing of residual water, corrosive environment, or other conditions beyond the control of the manufacturer.
6. Reimbursement for warrantable replacement parts not supplied by the manufacturer.
7. Shipping damage, or damage as a result of abuse in transporting the unit.

The manufacturer does not warrant that the goods sold are merchantable or fit for any particular purpose, and makes no warranties other than as stated in this section.

All other warranties, guaranties, or representations, express or implied, by operation of law or otherwise, are expressly disclaimed.

If circumstance warrants, the manufacturer may opt to refund the purchase price of such goods. Where applicable, as indicated above, the manufacturer will pay return transportation charges on returned goods not exceeding the transportation charges applicable to ship from original destination unless the returned goods are free from defect and conform to specifications. Be sure to review this instruction booklet. Returned goods which are found by the manufacturer to be free from defect and to conform to specifications shall be held for Purchaser's shipping instructions, which shall be furnished promptly upon request.

The manufacturer's liability shall in no event extend beyond replacement, repair or refund of the purchase price and shall not be liable under any circumstances for special, contingent, incidental or consequential damages, nor for losses, damages, or expenses directly or indirectly arising from the use of the goods, including without limitation, warehousing, labor, handling and service charges, die, equipment, or machine breakage, nor for costs, lost profits or loss of good will. The use of substitute parts and/or filters in this product voids all warranties and performance claims. The remedies set forth herein are exclusive.

Any replacement parts supplied under warranty will be warranted for the balance of the product's warranty.

Establishing the proof of purchase date for warranty purposes is the responsibility of the end-use customer, failing which, the effective date will be based upon the date of manufacture plus thirty (30) days. Retain your bill of sale as proof of purchase.

For warranty information and assistance contact B-Air and request the assistance of a technician at 877.800.2247 or email [warranty@b-air.com](mailto:warranty@b-air.com)

**SPECIFICATIONS**

Model	VG 1500
Water Removal Capacity (90°F 90%RH)	150ppd
Water Removal Capacity (80°F 60%RH)	76ppd
Power	7.3 amps, 115 volts
Refrigerant	R410a
Operating Range	33°–100°F
Max Process Air	235CFM
Power Cord	25 ft.
Net Weight	84 lbs
Dimensions (W×D×H)	22.5 × 20 × 32 in.
Construction	Roto-molded Polyethylene

## TROUBLESHOOTING GUIDE – COMMERCIAL DEHUMIDIFIER

**WARNING:** Some diagnostics contained herein are for the guidance of qualified service personnel only. Improper troubleshooting or servicing could result in fire, shock, explosion, or mechanical injury hazards that can cause personal injury or death.

PROBLEM	CAUSE	SOLUTION
Dehumidifier does not operate	No Power to appliance	Connect plug to power socket
	Switch not turned on	Switch on
	E4 error is displayed	Check drainage flow
Dehumidifier collects little water	Insufficient working time	Allow more working time
	Filter is blocked	Clean filter
	Low ambient temperature	Increase ambient temperature
	Condensate hose is blocked	Check hose for restrictions
Dehumidifier is operating but room is not drying	Doors and windows are open	Seal room from external areas

### WARNING:

In the event of a fault code, contact your service agent.

CODE	E1	E2	E3	E4
<b>Error Message</b>	Coil sensor error	Humidity sensor error	Low or no refrigerant	Water pump fault or blockage
<b>Display Reading</b>	Flashes every 30 sec's	Flashes every 30 sec's	Flashes continually	Flashes continually
<b>Reason</b>	Timed defrost mode. The dehumidifier is working correctly.	50% R.H displayed Continuous mode in operation	Turn power OFF. Then turn ON again.	Dehumidifier will turn OFF automatically. The fault must be rectified before operation can commence.

\*This troubleshooting guide is intended for use by qualified service personnel.